

C964 C962 C960 PWN	P/N 37329	REV: A
DRAWN BY: K. SNYDER	DATE: 11/6/95	SHEET 1 OF 5

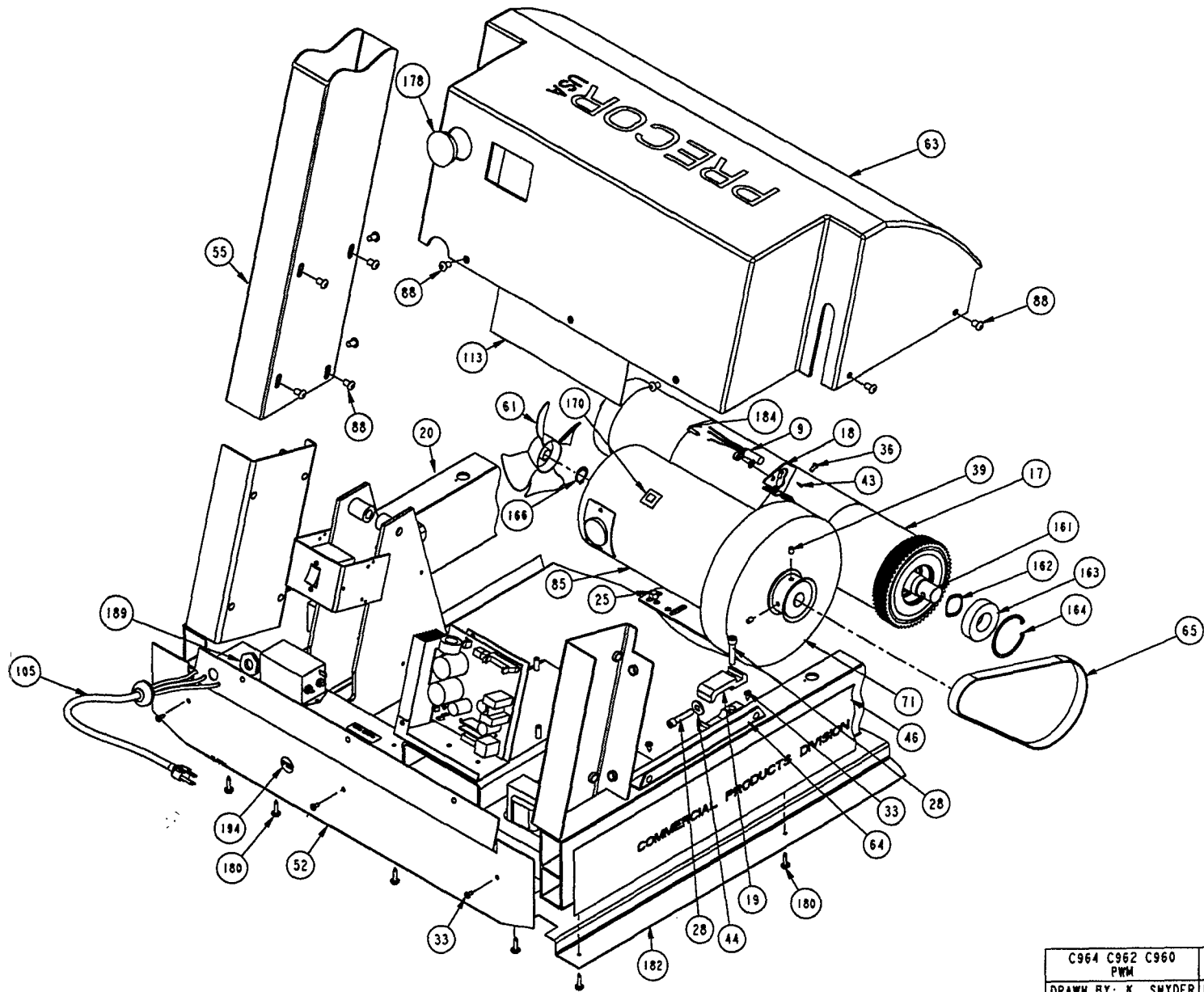

C964 C962 C960 P/W	P/N 37329	REV: A
DRAWN BY: K. SNYDER	DATE: 11/9/95	SHEET 2 OF 5

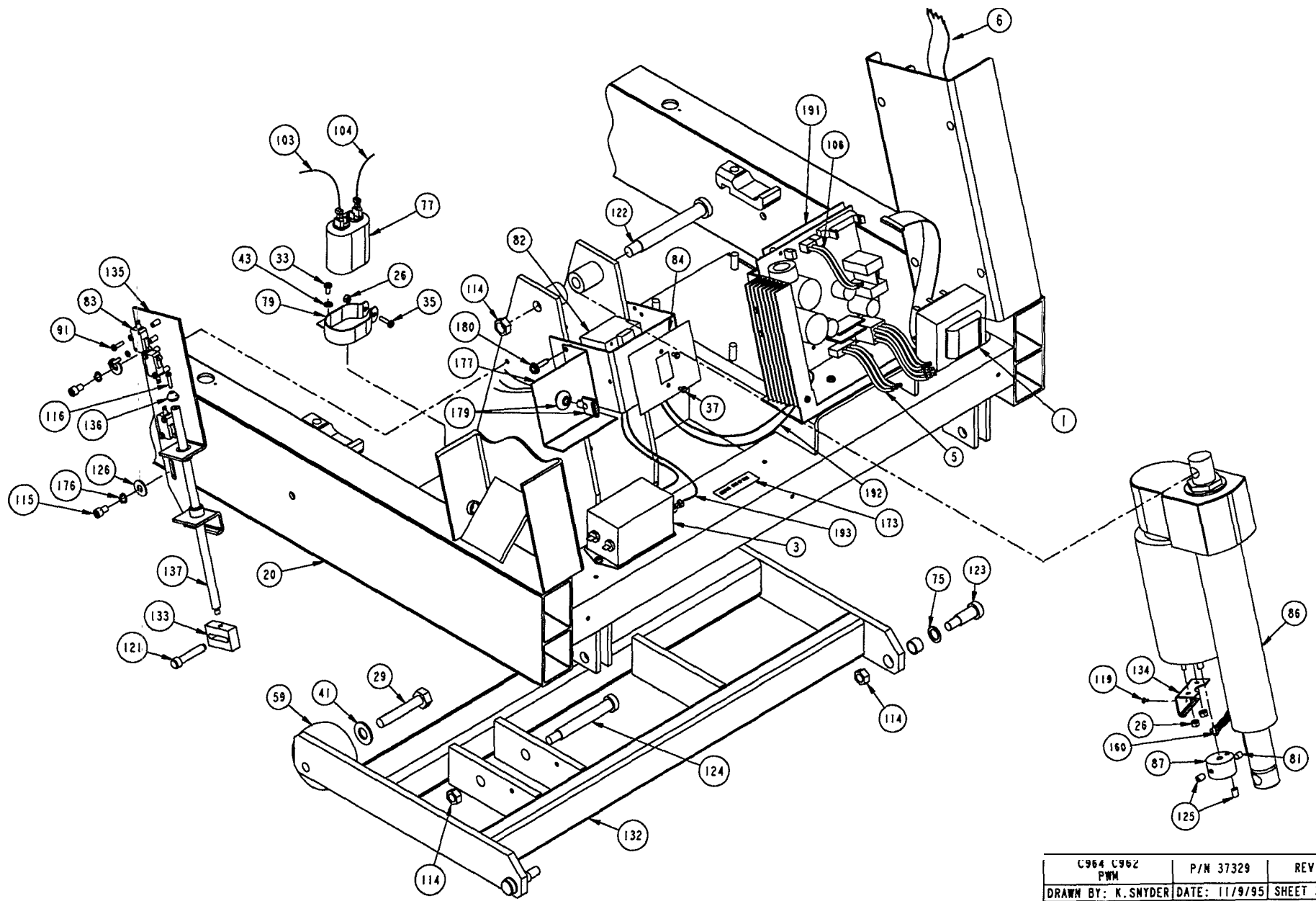

C964 C962	P/M 37329	REV: A
PWM		
DRAWN BY: K. SNYDER	DATE: 11/9/95	SHEET 3 OF 5

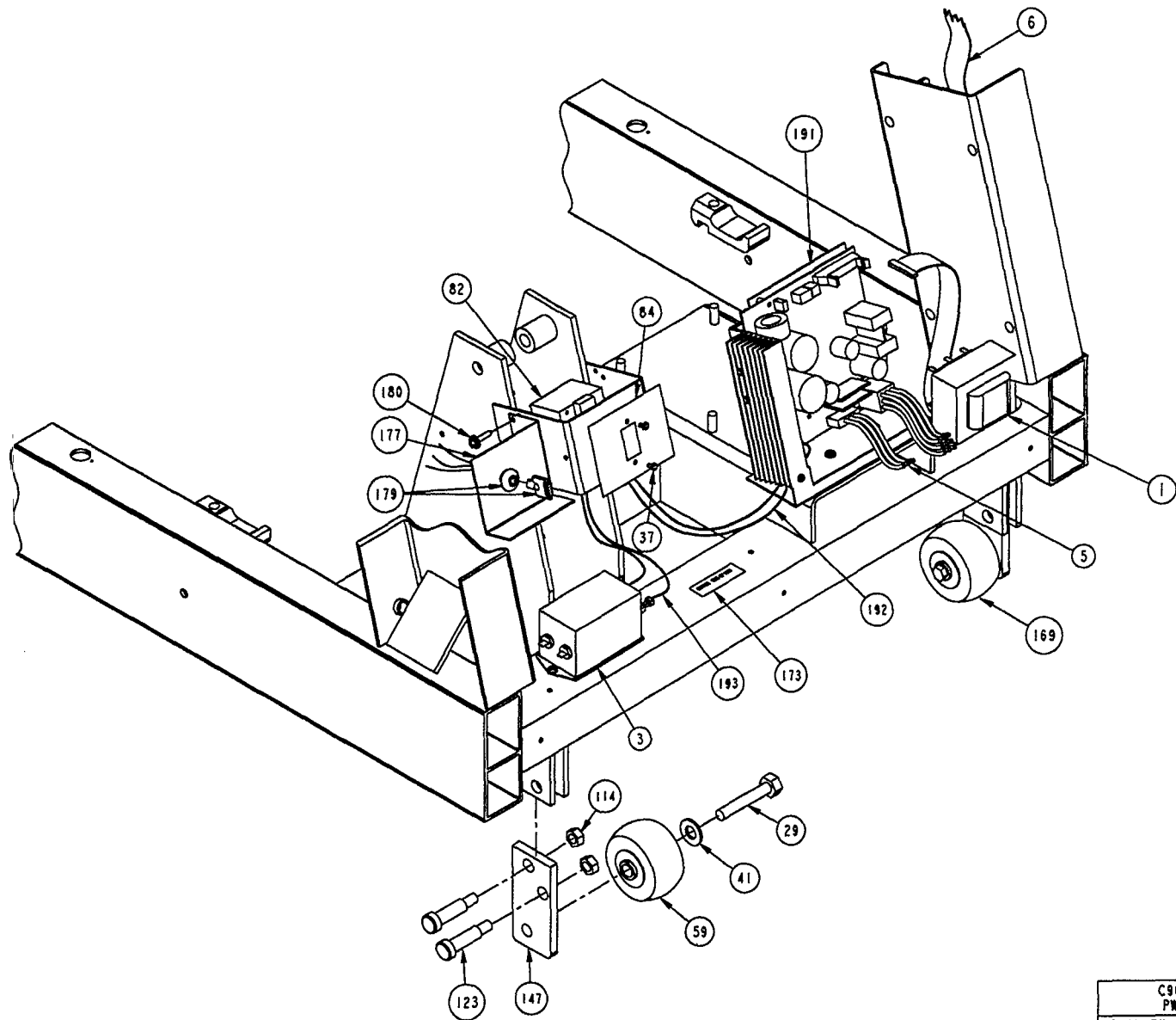

C960 P/M	P/M 37329	REV: A
DRAWN BY: K.SMYDER	DATE: 11/9/95	SHEET 4 OF 5

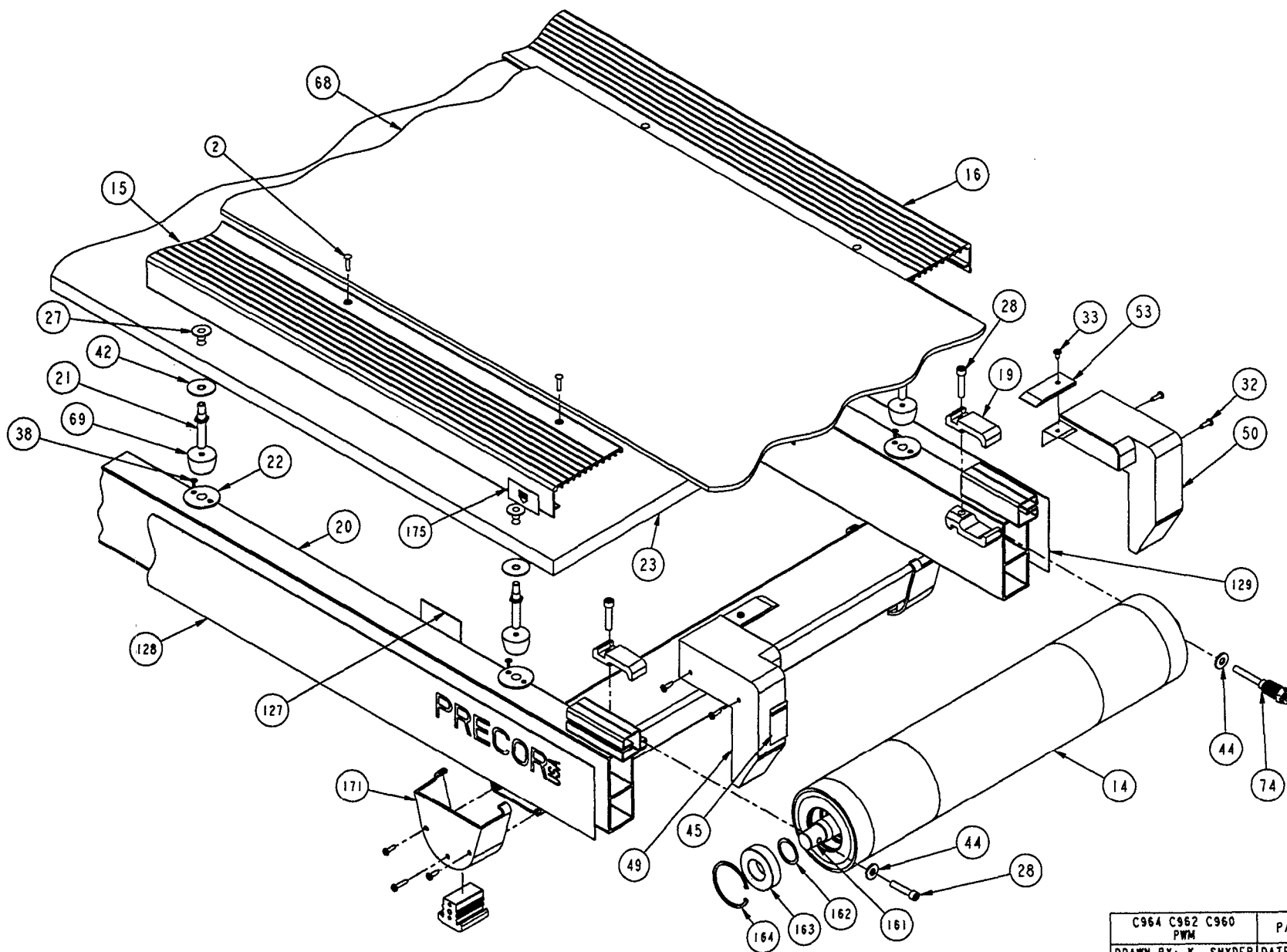

C964 C962 C960 PWM	P/N 37329	REV: A
DRAWN BY: K. SNYDER	DATE: 11/9/95	SHEET 5 OF 5

C962 (240 VAC, version 2) (serial code 1P)

Part Number	Description	Bubble Number
37068-104	ASSY,TRANSFORMER,PWM,240V	1
DCKN019-100	SCREW,WOOD #10X1, L=1.00	2
11224-101	FILTER,PWR LINE,250VAC,16A	3
37714-102	ASSY,CBL,83 ,DISPLAY,PWM	6
33868-108	ASSY, CABLE, SPEED SENSOR,PWM,	9
33490-102	ASSY, TAKE-UP ROLLER, C960/SP	14
33560-102	ASSY, DRIVE ROLLER, C960/SP	17
33873-104	STUD, BED SPRING	21
36103-105	BUSHING,BED,C960	22
48401-102	BED, ASSEMBLED, BLACK C96XI	23
59001-102	ASSY,SAFETY CLIP	24
KGCN031-027	LOCKNUT,STARWASHER,5/16-18,1/2	25
KANNN038-044	NUT, TEE, 3/8-16	27
CAKN031-150	SCREW,SKHD,5/16-18X1.50,BLK ZN,LK	28
TAKT031-250	SCREW,BTHD,5/16-18X2-1/2,BLK ZN	30
TAKN019-063	SCREW,BTHD,10-24X5/8,BLK ZN	31
PBKN019-075	SCREW,S/T,#10X3/4,PANHD,PHIL,	32
PBKN019-050	SCREW,S/T,#10X1/2,PANHD,PHIL,	33
PGKN016-050	SCREW,S/T,#8X1/2,TRS,PHIL,BLK	34
MHCN019-038	SCREW,MCH,10-32X3/8,PANHD,PHIL	36
MGCE013-025	SCREW,MCH,6-32X1/4,PANHD,PHIL,	37
PPCN011-038	SCREW,S/T,#4X3/8,FLTHD,PHIL,	38
EMKN008-010	SCREW,SET,M8-1.25XM10,KNRLDCUP	39
WABCN044-006	WASHER, FEN. 7/16, ID=.500,	42
WATNN020-002	WASHER, LK-INT, #10, ID=.200,	43
WCCN031-008	WASHER, FLT, 5/16X.875X.083	44
33859-103	LABEL, SIDERAIL, FRONT, C960	46
10736-501	WASHER, RAIL, C960/SP,PT	48
33528-105	ENDCAP, LEFT REAR, PT C960	49
33528-106	ENDCAP, RIGHT REAR, PT	50
33644-106	WELDMENT, BASEPLATE, PAINTED,	51
50983-101	ASSY,CSAFE DISPLAY PLATE,C964	51
36400-103	GUARD, ETL COMPLIANCE	53
36400-104	GUARD, ETL COMPLIANCE PAINT	53
33735-201	WELDMENT, TARGA LEFT, PAINTED	54
33735-202	WELDMENT, TARGA RIGHT,PAINTED	55
33736-102	HANDRAIL, FRONT,PT	56
10123-102	CABLE TIE, 3-7/8 LONG,WHITE,NYL	57
37239-102	FAN, MOTOR, PWM, DL HUB	61
33566-102	CAP, END, REAR CROSS	62
59007-105	ASSY, HOOD & KEYLOC C960	63
33849-102	BRACKET, HOOD C960	64
10737-103	BELT, DRIVE, MOTOR, C960	65
36355-127	RUNNING BELT, SIEGLING, 138.10 X 20	68
33563-102	SPRING, BED SUPPORT	69
38756-101	ASSY, FLYWHEEL,964I	71
ACHN244-008	RING,RETAINER	74
37251-103	MOTOR,220VDC,3.0 HP,12 AMPS	85
33657-106	MOTOR,LIFT 240V,WARNER	86

33701-102	MAGNET,HUB,C94X/C96X	87
TAKN031-050	SCREW,BTHD,5/16-18X1/2,BLK ZN	88
KDCN011-008	LOCKNUT, FULL, 4-40,ZINC PLT	89
MGCE011-075	SCREW,MCH,4-40X3/4,PANHD,PHIL,	91
LANN018-250	PIN, DOWEL, 3/16 X 2.50	92
10731-101	SWITCH,MICRO,	93
59000-165	ASSY, HOUSING & KEYPAD W/O	94
33559-104	CAM, SAFETY SWITCH, C96X	95
33729-113	LABEL, DISPLAY ENGLISH C962	97
33663-115	PCA,DISPLAY,CLUB,C962I	98
37114-107	ASSY, DISPLAY ENCLOSURE	98
44270-101	WHEEL, LIFT	111
CAKN025-038	SCREW,SKHD,1/4-20X3/8,BLK ZN,LK	115
36382-103	FOOT, C960	118
RANN038-150	SCR,SHLD,1/2 X 1-1/2 ,HEXSC	123
59012-101	ASSY, LIFT PLATFORM, C960	132
33934-801	SHAFT, ACTUATOR, FINISH C960	137
WAGNN117-002	WASHER, WAVE, 1.50 OD X 1.17	162
10397-101	BEARING, ROLLER M TREAD	163
10133-124	RING,RETAINER	164
59003-101	ASSY, VELCRO, HOOK & LOOP C960	165
10133-102	RING,RETAINER,3/4,EXT	166
AAHN034-006	RING,RETAINER,3/4,EXT	166
10332-101	MOUNT, CABLE TIE	170
59006-101	ASSY, REAR FOOT C960	171
37437-102	LABEL, FUSE, FIRE HAZARD	173
37621-101	LABEL,GROUND EFFECTS,OVAL,DURO-LENZ	175
36451-101	BRACKET, SECURITY KEY C960	177
WCKN025-007	WASHER, PLAIN 1/4 BLACK	178
37126-102	ASSY, SECURITY LOCK, PWM	179
PKCN019-075	SCREW,S/T,#10X.75,WSHXHD,ZN	180
36450-103	SAFETY GUARD, ALUM, C960	182
CCKN025-075	SCREW,SKHD,1/4-20X0.75,BLK ZN,LK	184
WACPN028-003	WASHER,.281"ID,.500"OD,.031"	186
TAKN025-250	SCREW,BTHD,1/4-20X2-1/2,BLK ZN	190
37805-103	ASSY, LWR, ELECT, MODULE, PWM	191
59020-103	KIT,UPGRADE,LOWER ELECTRIC	191.01
37042-101	LABEL, PWM EQUIPPED PRODUCT	194
37436-101	LABEL, CHASIS NEUTRAL	196
59008-104	KIT, LIFT REVOLUTION SENSOR,	197
37564-101	LABEL, ON-OFF POSITION	198
37648-101	ASSY, CABLE, FAN	199
37657-101	BRACKET, COOLING FAN	201
10186-102	WRENCH, ALLEN, 1/4	214
34065-101	INSTRUCTIONS, HANDRAIL OPTION	215
35628-102	HANDRAIL, SHORT, PAINTED	216
35629-102	HANDRAIL, LONG, PAINTED	217
10123-101	CABLE TIE,11 LONG,WHITE,NYL	218
36192-101	BUSHING, SPANNER	220
20038-101	SPRING, MOTOR BRUSH, 3 HP	226
20047-101	KEY, SECURITY	228

59011-105	ASSY, SPEED SENSOR, 120V LARGE	229
20029-102	BELT, DRIVE, LIFT, DAYCO	232
38844-502	COVER,CUT-OUT,C-SAFE,BLK,PT, OOH	243
38876-501	GASKET,RUBBER,HALL EFFECT	244
20002-106	BRUSH, MOTOR, PAC SCI, C960	990